

TOP MULTI-EVOTECH

Multi-stage automatic submersible pumps

-  Clean water
-  Domestic use
-  Civil use

**AUTOMATIC
START & STOP**



PERFORMANCE RANGE

- Flow rate up to **120 l/min** (7.2 m³/h)
- Head up to **42 m**
- Restart pressure: **1.5 bar**

APPLICATION LIMITS

- **5 m** maximum immersion depth
- Maximum height between pump and point of use **10 m**
- Maximum liquid temperature **+40 °C**
- Suction down to **84 mm** above ground level
- Continuous service **S1**

CONSTRUCTION AND SAFETY STANDARDS

Complete with:

- **10 m** long power cable
- internal electronic device for pump starting (when tap opened) and stopping (when tap closed)
- threaded connector 1¼" (delivery)
- hose connector Ø 35 mm

EN 60335-1
IEC 60335-1
CEI 61-150

EN 60034-1
IEC 60034-1
CEI 2-3



CERTIFICATIONS

Company with management system certified DNV
ISO 9001: QUALITY
ISO 14001: ENVIRONMENT



INSTALLATION AND USE

TOP-MULTI-EVOTECH pumps are recommended for pumping **clean water** and liquids that are not chemically aggressive for the materials from which the pump is made.

Because of their high efficiency and reliability they are suitable for use in applications such as domestic water supply from reservoirs, tanks or relatively deep wells, for drawing rain water from cisterns to water gardens or for use in irrigation systems, etc.

An internal electronic device starts or stops the pump automatically when the tap is opened or closed.

OPTIONS AVAILABLE ON REQUEST

- Other voltages or 60 Hz frequency
- **KGE - Floating suction kit**



Kit includes:

- 1.5 metre long PVC hose (Ø 30 mm)
- stainless steel suction filter
- polyethylene spherical float
- flexible hose fittings Ø 30 mm

TOP MULTI-EVOTECH with KGE kit for aspiration at about 10 cm below the water surface, preventing the suction of any floating waste or sediment on the bottom of the tank thus avoiding any damage to the pump.

PATENTS - TRADE MARKS - MODELS

- Patent n° EP2990653
- Registered Trade Mark n° 0001334477 TOP MULTI®

CHARACTERISTIC CURVES AND PERFORMANCE DATA

50 Hz n= 2900 min⁻¹

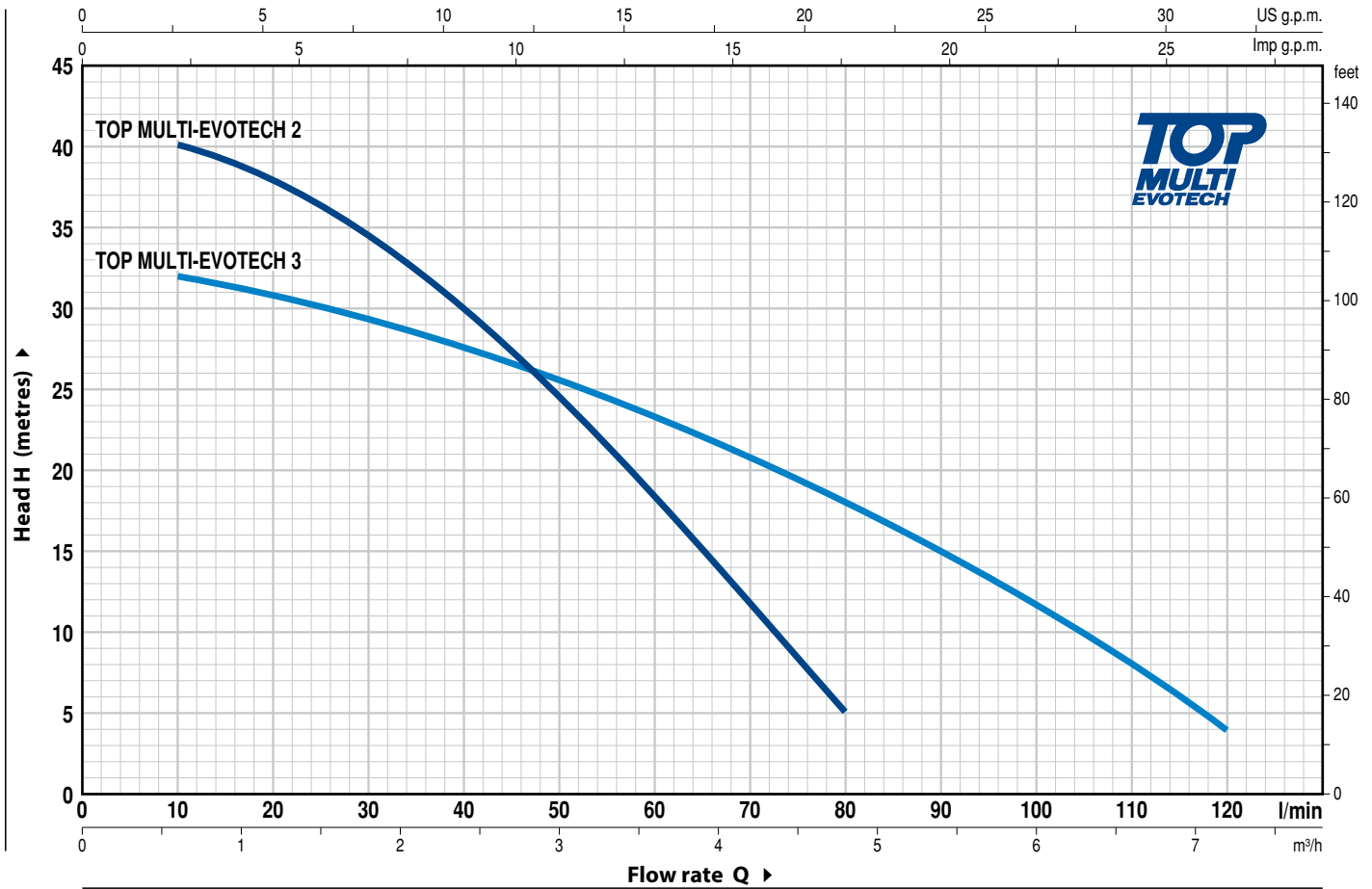

MODEL Single-phase	POWER (P ₂)		Q	0	0.6	1.2	1.8	2.4	3.0	3.6	4.2	4.8	5.4	6.0	6.6	7.2
	kW	HP		0	10	20	30	40	50	60	70	80	90	100	110	120
TOP MULTI-EVOTECH 2	0.55	0.75	H metres	42	40	38	34	30	24	18	11.5	5				
TOP MULTI-EVOTECH 3	0.55	0.75		33	32	31	29.5	28	25.5	23	20.5	18	15	12	8	4

Q = Flow rate H = Total manometric head

Tolerance of characteristic curves in compliance with EN ISO 9906 Grade 3B.

TOP MULTI-EVOTECH

POS. COMPONENT

CONSTRUCTION CHARACTERISTICS

1	DELIVERY BODY AND SUCTION BODY	Glass fibre reinforced technopolymer
2	PUMP BODY AND BASE	Glass fibre reinforced technopolymer
3	MOTOR SLEEVE	Stainless steel AISI 304
4	IMPELLERS	Noryl FE1520PW
5	DIFFUSERS	Noryl FE1520PW complete with anti-wear ring
6	MOTOR SHAFT	Stainless steel EN 10088-3 - 1.4104
7	ELECTRONIC DEVICE	<p>TOP MULTI-EVOTECH pumps are fitted with an internal electronic device which starts the pump when the pressure of the system falls below 1.5 bar (eg. when opening a tap) and stops it when the flow falls below 3 litre per minute.</p> <p>It protects the pump:</p> <ul style="list-style-type: none"> – against dry running; – against blockage: after long periods of pump inactivity the electronic device starts the pump every 48 hours for 10 seconds.

8 TWO MECHANICAL SEALS SEPARATED BY AN OIL CHAMBER

Seal Model	Shaft Diameter	Position	Stationary ring	Rotational ring	Elastomer
STA-13R	Ø 13 mm	Motor side	Ceramic	Graphite	NBR
STA-12R SG	Ø 12 mm	Pump side	Silicon carbide	Graphite	NBR

9 BEARINGS

6202 ZZ - C3 / 6201 ZZ

10 CAPACITOR

Capacitance
(220-230 V or 240 V)
12.5 µF 450 VL

11 ELECTRIC MOTOR

TOP MULTI-EVOTECH: single-phase 220-230 V - 50 Hz with thermal overload protector incorporated into the winding.

- Insulation: class F
- Protection: IP X8

12 POWER CABLE

"H07 RN-F" with Schuko plug
Standard length 10 metres

13 THREADED CONNECTOR

Threaded connector 1¼"

14 HOSE CONNECTOR WITH RING NUT

Ø 35 mm hose connection

15 ANTI-VIBRATION SUPPORTS

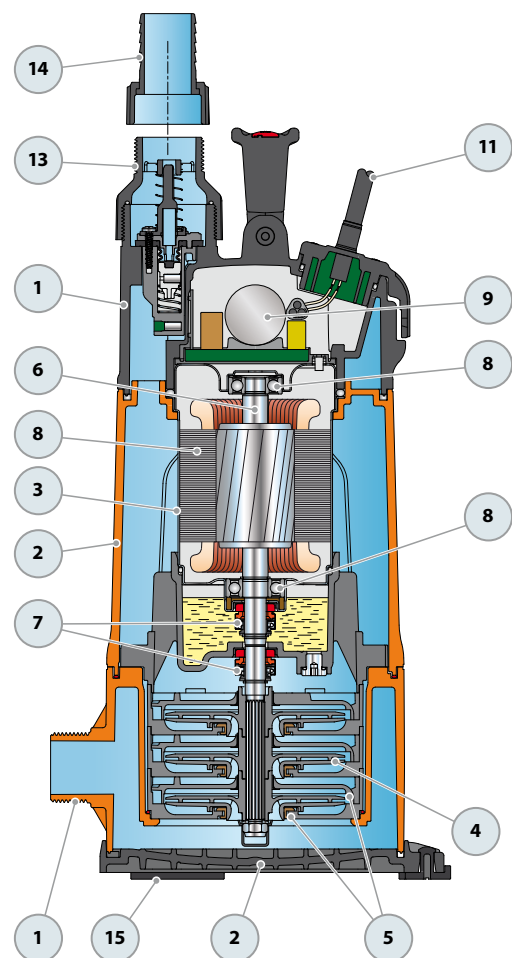

DIMENSIONS AND WEIGHT

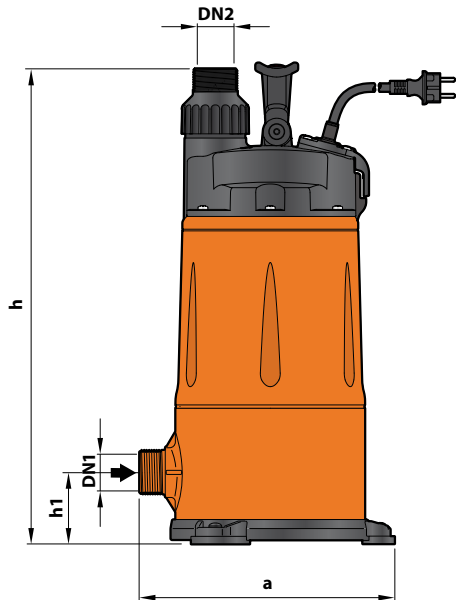

Standard installation

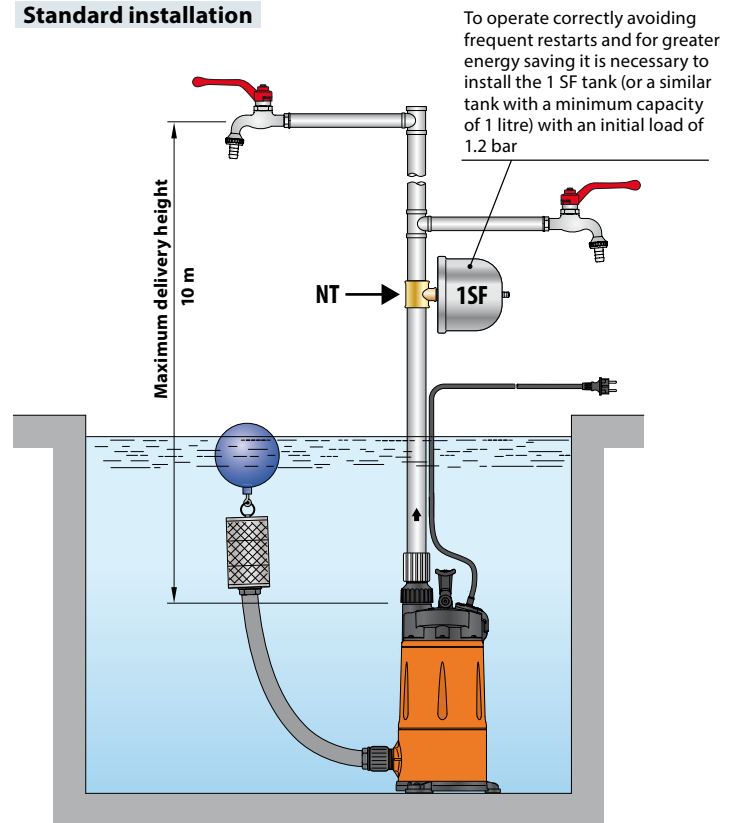

MODEL	PORTS		N° STAGES	DIMENSIONS mm			kg
	DN1	DN2		a	h	h1	
Single-phase							
TOP MULTI 2-EVOTECH	1¼"	1¼"	3	239	442	68	9.9
TOP MULTI 3-EVOTECH							

ABSORPTION

MODEL	VOLTAGE
Single-phase	230 V
TOP MULTI 2-EVOTECH	3.4 A
TOP MULTI 3-EVOTECH	3.6 A

PALLETIZATION

MODEL	GROUPAGE
Single-phase	n. pumps
TOP MULTI 2-EVOTECH	60
TOP MULTI 3-EVOTECH	60